



AQUBE® MV8 TWIN

Fully automatic twotank economy system with two separate circuits and fourfold ASYNCHRO® rotor system

Cleans screens, stencils and PumpPrints from SMD paste, SMD adhesive, soldering support substances, oil & dust

Capacity: 2 stencils up to 900 x 800 x 50 mm, 35" x 32"

Part number: 0905AQ8MV12

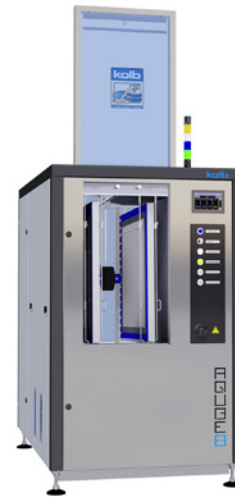

Certifications:

This system in its basic version was certified for its energy and water-saving processing, for easy operability and for the standard integration of comprehensive safety features.

- * Two tank system with two separate circuits
- * Intelligent network connectivity for implementation in industry 4.0 smart factories
- * Fully automatic 4step process: cleaning, MediumWipe®, rinsing, CWA® supercharger compression drying
- * Vertical PTFE mounted rotor system with four asynchronous spray rotors for thorough wetting (no blind spots)
- * Short cycle times (approx. 5 min / normal contamination) due to placing the cleaning goods close to the spray rotors
- * Water free operation possible with a suitable cleaning / rinsing detergent
- * Process and service intervals PLC controlled
- * Event issuing and software control via touch screen
- * Safe installation close to the production line / screen printer possible; no special protection required
- * EDGELESS Design and VARlccess® service access: maximum capacity, easy maintenance on a very small footprint

Key applications

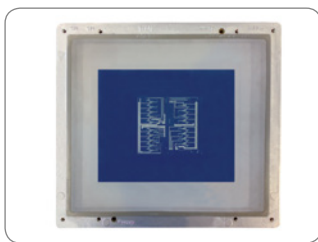

Screens



Stencils



PumpPrints

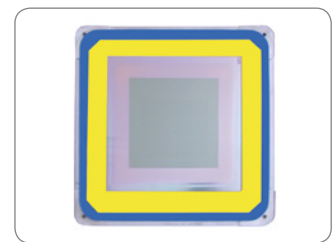

M-TeCK stencils

The new kolb AQUBE® series offer next-generation cleaning systems - even more efficient, even more compact, easy to handle and maintain, pre-equipped for extended water management and cyber-physically ready for the smart factory (SF ready).

kolb AQUBE® MV8 TWIN is a fully automatic system with a large process chamber for reliable precision cleaning of two screens, stencils, PumpPrints or other flat products. Removes quickly and thoroughly contaminations such as SMD-paste, SMD-adhesive, flux residues, stabilizer materials, flux, oil, grease or dust. AQUBE® MV8 TWIN cleans two stencils up to 900 x 800 mm (35 "x 32") in a very short cycle time, making it especially suitable for large-scale manufacturing.

PSE MV8 is a German engineered and manufactured machine with ClosedLoop water reprocessing and a two-tank and two separate circuits configuration which ensures short cycle times and makes this system the perfect economic choice for the cleaning of larger screens and stencils.

The cleaning system can be operated with all common electronics cleaning supplies (detergents / chemistry, etc.) which are approved by the manufacturer.





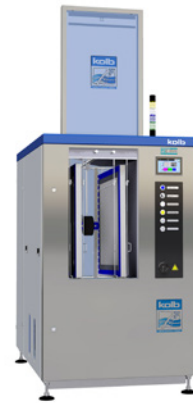

AQUBE® MV8 TWIN

Fully automatic twotank economy system with two separate circuits and fourfold ASYNCHRO® rotor system

Part number: 0905AQ8MV12



Application overview

Optional suitable	Most suitable	Optional suitable	Not suitable	Not suitable
				
Assembled PCBs Hybrids Misprints	Stencils Screens, PumpPrints Misprints	Solder frames Solder carriers Solder masks	ESD Boxes Containers Magazines	Condensation traps Filters Steel sheets

Optional suitable applications can also be optimally realized with the appropriate options.

Cleaning (key process 1): From the cleaning tank (A) the cleaner liquid is sucked by a magnetically coupled pump unit and routed with a controllable volume flow through a separate circuit into the ASYNCHRO® spray rotor nozzles. Their geometry ensures a comprehensive and thorough cleaning, even in inaccessible and critical areas. After the washing procedure, the valve switchover of the process chamber undocks the cleaning circuit until the next process run.

MediumWipe® (intermediate process 2): The remaining cleaner is blown off from the clean products and blown out of the cleaner circuit and recirculated into the cleaning tank before the valve switchover closes.

Rinsing with tap water (key process 3): From the rinsing tank (tank B) the water is pumped through the separate second circuit into the spray rotors. Tap water has (compared to DI / DM water) the advantage of lower surface tension and thus flushes also critical points as low standoffs and apertures more efficient.

MediumWipe® (intermediate process 2): The remaining water is blown off from the products and blown out of the cleaner circuit and recirculated into the rinsing tank.

Final rinsing with DI / DM water (optional process): The DI / DM water is produced from tap water in an integrated MB-cartridge and flushes conducting ions of the previous processes. This process is repeated automatically until the remaining amount of ions falls below the programmed value.

MediumWipe® (optional intermediate process): Blowing off and recirculating the remaining DI / DM water into the rinsing tank.

Drying (key process 4): The purified products are dried with the patented CWA® (Compressed Warm Air) technology. The built-in special compressor compresses the ambient air. At the same time it collects the kinetic energy (frictional heat) of the paddle wheel in the unit, then presses the heated and compressed air into the rotor nozzles which were already used for cleaning and rinsing. There it blows off (pressure) and evaporates (heat) the residual moisture. This method is energetically and constructively highly efficient, as it uses the "waste heat" of the compressor rotation and the compressed air as driving power for the rotors. In addition, a system equipped with CWA® technology requires no additional hardware and no external compressed air connection for the MediumWipe® process.

Maintenance: The system has a large maintenance door on the right side. In the maintenance area among others are the pump-out set, the optional re-dosage unit with space for a 25 liter detergent and a 5 l additive container as well as the MB cartridge for DI / DM water processing. Tank levels as well as pressure values and maintenance cycles are monitored by the PLC and displayed on the touch screen.



AQUBE® MV8 TWIN

Fully automatic twotank economy system with two separate circuits and fourfold ASYNCHRO® rotor system

Part number: 0905AQ8MV12

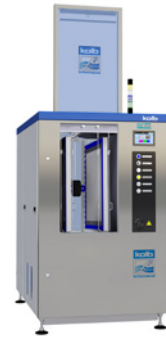

Main standard features

- PowerSpray® technology bundle: magnetically coupled pump unit, eightfold ASYNCHRO® volume-spray rotor system, "Option101" softwareprogram (101 freely selectable programs)
- EATON Programmable Logic Controller (PLC)
- Smart Factory ready: DNAccess® (standard) for remote control (see options) and traceability with retractable touch monitor and integrated industrial PC (see options)
- High resolution 7" (1.024 x 600 mm) display with capacitive multi-touch
- Fourfold alternating LED status light bar integrated in the system frame
- Full flow coarse filter (process chamber)
- Sediment filter for cleaning tank (A)
- MediumWipe® unit for further optimization of detergent and rinsing fluid use
- CWA® supercharger compression drying
- ClosedLoop reprocessing of cleaning and rinsing fluids
- HMA software and pre-equipping for HMA hardware (Heavy Metal Adsorber) for the cleaning circuit (see options)
- Spare space for DI / DM water processing cartridge
- Safety features: safety interlock on the process chamber door, overflow alarm for all tank sections, overheating protection for all heating and drying elements, end switches for all motor-driven valves and drives, personnel protection insulation
- VARAccess® service access with right and left-hinged side doors as well as unhinging possibility for side doors, front panel, and rear supply rail
- EDGELESS housing design. Doors, cover panels and hinges without edges, depot for traceability scanner and monitor in the right side panel
- Process sections made of electrolysis resistant elements

■ = AQUBE®-exclusive components (vs. kolb PSE Economy series)

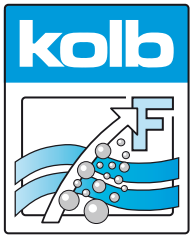

AQUBE® MV8 TWIN

Fully automatic twotank economy system with two separate circuits and fourfold ASYNCHRO® rotor system

Part number: 0905AQ8MV12

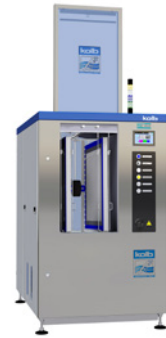

Main options

- | |
|--|
| <input type="checkbox"/> Adjustable DI / DM water mixing and blending unit |
| <input checked="" type="checkbox"/> AOSelection® bundle to separate mandatory disposable and public sewage network dischargeable rinse water |
| <input type="checkbox"/> Automatic re-dosage unit for 25 l detergent and 5 l additive container |
| <input type="checkbox"/> Descaling unit to reduce the lime content in the rinsing water |
| <input type="checkbox"/> Drip & storage reservoir |
| <input type="checkbox"/> Exchange for rinse water and pump out unit |
| <input type="checkbox"/> Exhaust unit |
| <input type="checkbox"/> Heater for tank A (cleaning) |
| <input checked="" type="checkbox"/> HMA filter (Heavy Metal Adsorber) unit for the cleaning circuit |
| <input type="checkbox"/> MB / DI cartridge for deionized (DI) and demineralized (DM) water |
| <input type="checkbox"/> Noise insulation |
| <input checked="" type="checkbox"/> Optional lacquering (frame rack and coverings) |
| <input checked="" type="checkbox"/> Remote Control (remote monitoring, mailing, etc.) |
| <input type="checkbox"/> Status light fivefold to display the current process state |
| <input checked="" type="checkbox"/> Traceability unit with PLC data scanner and retractable touch monitor and industrial PC with Intel processor |

■ = AQUBE®-exclusive components (vs. kolb PSE Economy series)



AQUBE® MV8 TWIN

Fully automatic twotank economy system with two separate circuits and fourfold ASYNCHRO® rotor system

Part number: 0905AQ8MV12

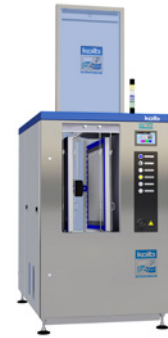

Internal rinse water processing (standard)

Options* for water management

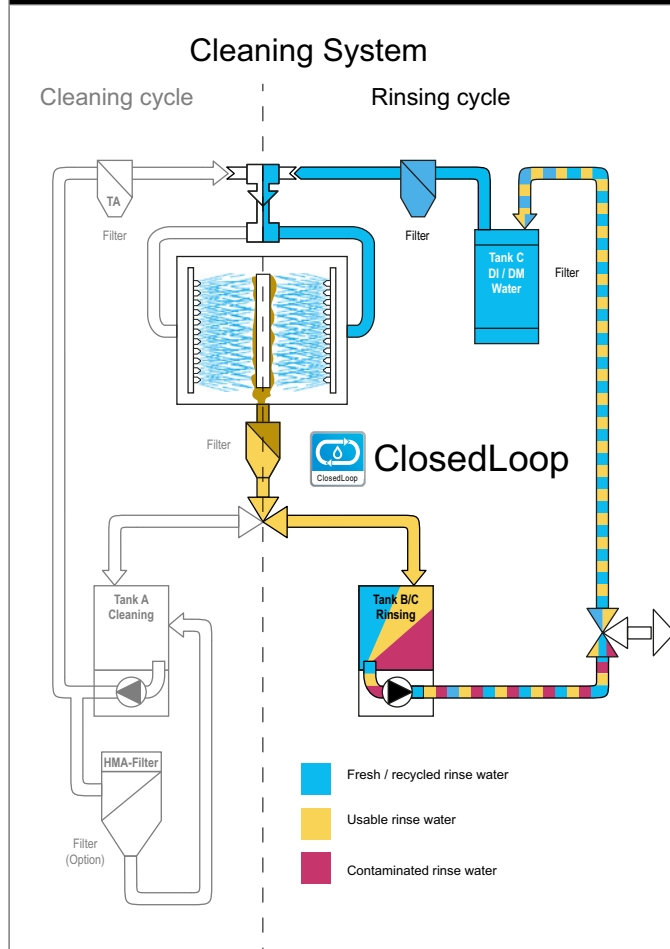

- **AOSelection® unit**
separates mandatory disposable sewage water from rinse water which can be discharged into a public sewage network.

■ = AQUBE®-exclusive components (vs. kolb PSE Economy series)

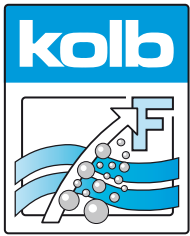

AQUBE® MV8 TWIN

Fully automatic twotank economy system with two separate circuits and fourfold ASYNCHRO® rotor system

Part number: 0905AQ8MV12

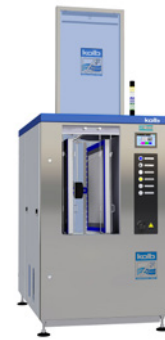

Technical data

Technology base	kolb PowerSpray®
Capacity	2 stencils up to 900 x 800 x 50 mm, 35" x 32"
Process chamber dimensions	W 550 • D 1000 • H 875 mm
Usable chamber dimensions	2 slots: B 50 • T 800 • H 900 mm
Volume tank A (cleaning)	ca. 75 l
Volume tank B (rinsing)	ca. 75 l
Power supply	400 V AC, 16 A CEE / 3PH / 50 or 60 HZ
Power consumption	ca. 4.1 kW
Control system	PLC (K & M)
Temperature load	up to 55°C
Filter system	up to three stage - 1. Full flow coarse filter < 2 mm, 2. Sediment filter inside the tank, 3. 20" fine filter (1 - 100 µm - process dependent)
Supply connection 1 (tap water)	3/8", hose connection 14 mm (prov. by customer: inlet water quality < 350 µS conductance value (< 10° dH) or option descaling unit)
Supply connection 2 (DI / DM water)	3/8", hose connection 14 mm (DI-net prov. by customer or bridging to tap water)
Rinse water drain connection	3/4", hose connection 25 mm with integrated pump out system
Exhaust connection	Ø 160 mm, exhaust capacity 200 to 300 m³ / h
Footprint	1.100 x 1.800 mm
Operating noise	74 dB (A), 70 dB (A) with option insulation
Empty weight	570 kg

Top view:

Space requirement cleaning system
 (a) = Exhaust 160 mm
 (b) = Status light

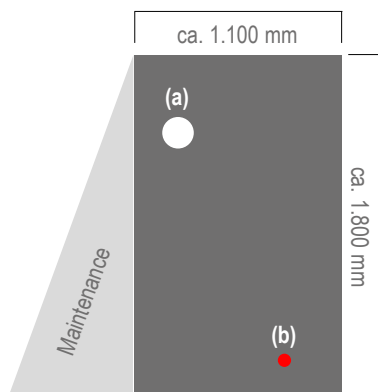

Front view: with optional status light (b)

